

ORDER NO. MSD891122000

Service Manual

Flexible Disk Storage Drive

JU-475-4

Panasonic

CONTENTS

		Page
	PART I	
1.	INTRODUCTION	1
2.	MODELS AND MODEL NUMBERS	1
	2.1 5.25inch FDD Series	1
3.	SPECIAL TOOLS	1
4.	OUTLINE OF MAINTENANCE	2
	4.1 Alignment Diskette	2
	4.2 Exerciser	2
5.	DIAGNOSTIC PROCEDURES	2
	5.1 Error Symptom Recognition	2
	5.2 Soft Error Detection and Correction	2
	5.3 Write Error	2
	5.4 Read Error	3
	5.5 Seek Error	3
	5.6 Interchangeability Error	3
6.	TROUBLE ANALYSIS	3
	6.1 Trouble Analysis Procedure	3
	6.2 Troubleshooting Flow Chart	4
	6.3 Trouble Analysis Table	5
7.	PREVENTIVE MAINTENANCE	6
8.	SPECIFICATIONS	6
9.	ADJUSTMENTS AND VERIFICATIONS	7
	9.1 Motor Speed Verification (Index Period)	7
	9.2 Write Protect Verification	7
	9.3 Head Output Verification	7
	9.4 Output Modulation Verification	8
	9.5 Resolution Verification	8
	9.6 Radial Alignment Verification and Adjustment	8
	9.7 Azimuth Verification	9
	9.8 Index Burst Verification and Adjustment	10
	9.9 Track 0 Sensor Adjustment	10
	9.10 Asymmetry Verification	11
10.	TEST POINTS	12
11.	PANASONIC ALIGNMENT DISKETTE	13
	PART II	
12.	REMOVALS AND INSTALLATIONS	14
	12.1 PCB Removal and Installation	14
	12.2 Front Plate and Handle Removal and Installation	14
	12.3 Track 0 Sensor Removal and Installation	15
	12.4 Collet Assembly Removal, Installation, and Adjustment	15
	12.5 Clamp Assembly Removal and Installation	16
	12.6 Write Protect Sensor Assembly and Index Sensor Assembly Removal and Installation	16
	12.7 Cartridge Guide Assembly Removal and Installation	17
	12.8 Stepper Motor Assembly Removal and Installation	18
	12.9 Head Carriage Assembly Removal and Installation	18 ~ 19
	12.10 Drive Motor Removal and Installation	20
	12.11 LED Assembly Removal and Installation	21
	12.12 Lifter Unit Removal and Installation	21
	12.13 Media Lifter Removal and Installation	22
	12.14 Media Sensor Assembly Removal and Installation	22
13.	EXPLODED VIEW	23
14.	REPLACEMENT PARTS LIST	24
15.	REPLACEMENT PARTS LIST FOR PCB	25~26
16.	SCHEMATIC DIAGRAM	27
17.	CIRCUIT BOARD	28~29
18.	BLOCK DIAGRAM	30

PART. I

1. INTRODUCTION

This service manual consists of two parts, Part I covers maintenance description, adjustment procedures, and trouble analysis and Part II covers disassembly and reassembly procedures, parts list, and PCB circuits.

Part I encompasses maintenance instructions for all Floppy Disk Drive (FDD) models. Refer to the highlighted applicable items, and perform maintenance work on the FDD.

Note : This service manual is prepared for maintenance of the FDD.
Do not use this manual for judging pass or fail criteria in inspections.

2. MODELS AND MODEL NUMBERS

2.1 5.25inch FDD Series

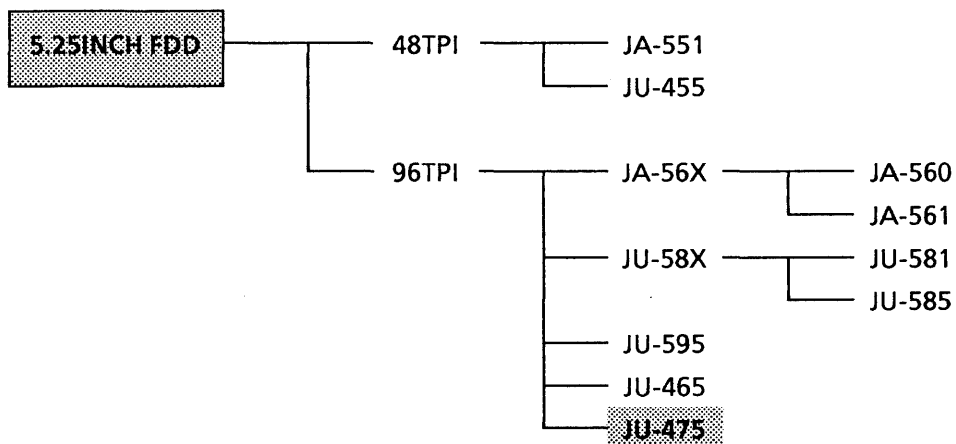

3. SPECIAL TOOLS

The following special tools are used for FDD maintenance.

Table 3 - 1 Special Tools

Tool	Part No.			Quantity
	5.25 inch (48TPI)	5.25 inch (96TPI)		
	JA-551 / JU-455	JA-561 / JU-465	JU-595 / JU-475	
Exerciser	FDD-EXT-35	*←	*←	1
Alignment diskette	817-128	817-560	*←	1~2
Data diskette	2D	2DD	2DD / 2HD	1~2
Oscilloscope (50 MHz)				1
Probe(10:1)				3
Frequency counter				1

Note: *← : Stand for the same as left.

4. OUTLINE OF MAINTENANCE

- The following tools are required for maintenance of an FDD.

4.1 Alignment Diskette

Alignment diskette is used for head actuator alignment and index sensor adjustment. Use the right diskette as shown in Table 8.1.

4.2 Exerciser

The exerciser enables you to make all adjustments and inspections necessary for an FDD. Its functions include the following.

- (1) Seek increment or alternate tracks
- (2) Read (but no data compare)
- (3) Write 1F or 2F (All "0"s or "1"s)
- (4) Head load (5.25inch FDD with optional head loader)
- (5) Recalibration to track 0

The exerciser has switches and indicators to execute a specified function.

5. DIAGNOSTIC PROCEDURES

5.1 Error Symptom Recognition

Errors that occur because of the wrong operating procedure, wrong programming, the use of a defective diskette, or soft errors due to external causes, such as contaminated air and random electrical noise, are often attributed to an FDD failure.

Unless a visual inspection of the FDD reveals an evident assembly fault or a defect, always confirm errors with another good diskette, and another known good FDD.

5.2 Soft Error Detection and Correction

Soft errors are normally caused by the following.

- (1) Contamination between read/write heads and diskette. This kind of contamination can be easily eliminated by the liner in the diskette. Please follow the appropriate procedures provided with the cleaning diskette.
- (2) Random electrical noise, normally a few microseconds or less.
- (3) Small defects in written data and/or track not detected during write operation may cause soft errors during read.
- (4) Faulty grounding of the FDD or host system can also cause soft errors.
- (5) Wrong motor speed is another cause of soft errors.

Take the following steps on the controller side to recover from the soft errors mentioned above.

- (1) Read the track again ten times or until the data is recovered.
- (2) If step (1) above fails to recover the data, access the adjacent track. Then return the head to the original track.
- (3) Repeat step (1).
- (4) Any error that cannot be corrected by the above procedure is irrecoverable.

5.3 Write Error

If an error occurs during write operation, it is usually detected during the next revolution by performing a read operation called write check. To correct an error, write again and repeat a write check operation. If the result is unsatisfactory after ten or more write operations, perform a read operation on another track to determine whether it is the diskette or the drive that is wrong. If an error persists, replace the diskette and repeat the above procedure.

If the error still persists, assume the FDD defective. If the error is corrected, the diskette is defective. It can be thrown away.

5.4 Read Error

Most read errors are soft errors. Data can be recovered by following the recovery procedure in section 5.2.

5.5 Seek Error

Seek errors are caused by the following.

- (1) Stepper motor or stepper motor drive circuit is faulty.
- (2) Faulty Carriage

There are two ways to recover from a seek error. One is to recalibrate to track 0, and seek back to the original track. The other is to read the ID field, check the track number on which the head is located, and move the head away from it. Read it again.

5.6 Interchangeability Error

Data which is written by one FDD may not be read by another. This error is called a interchangeability error, which can be caused mostly by the following reasons, which should be checked as follows.

- (1) Head misalignment: Refer to Adjustments and Confirmation section 9.6.
- (2) Head output too low: Refer to Confirmation section 9.3.
- (3) Motor speed difference: Refer to Adjustments and Confirmation section 9.1.
- (4) Format incompatibility.

6. TROUBLE ANALYSIS

To determine the cause of trouble whether it lies in the FDD, diskette, or controller, replace the diskette and the FDD with good ones. If the FDD is assumed faulty as a result, follow the procedure below.

6.1 Trouble Analysis Procedure

FDD trouble may occur in any of the following ten forms.

- (1) Index detection failure
- (2) I/O 34pin signal failure (Disk Change / Ready / Media In / Media Out)
- (3) Track 0 undetectable
- (4) No seek
- (5) No write
- (6) No read
- (7) Read error
- (8) IN USE LED won't light.
- (9) Write protect undetectable
- (10) No head load (5.25inch FDD with optional head loader)
Check with the troubleshooting flowchart in section 6.2.

CAUTION:

Be sure to switch the power off before removing an FDD or PCB from the operating system.

6.2 Troubleshooting Flow Chart

Table 6 - 1 Troubleshooting Flow Chart

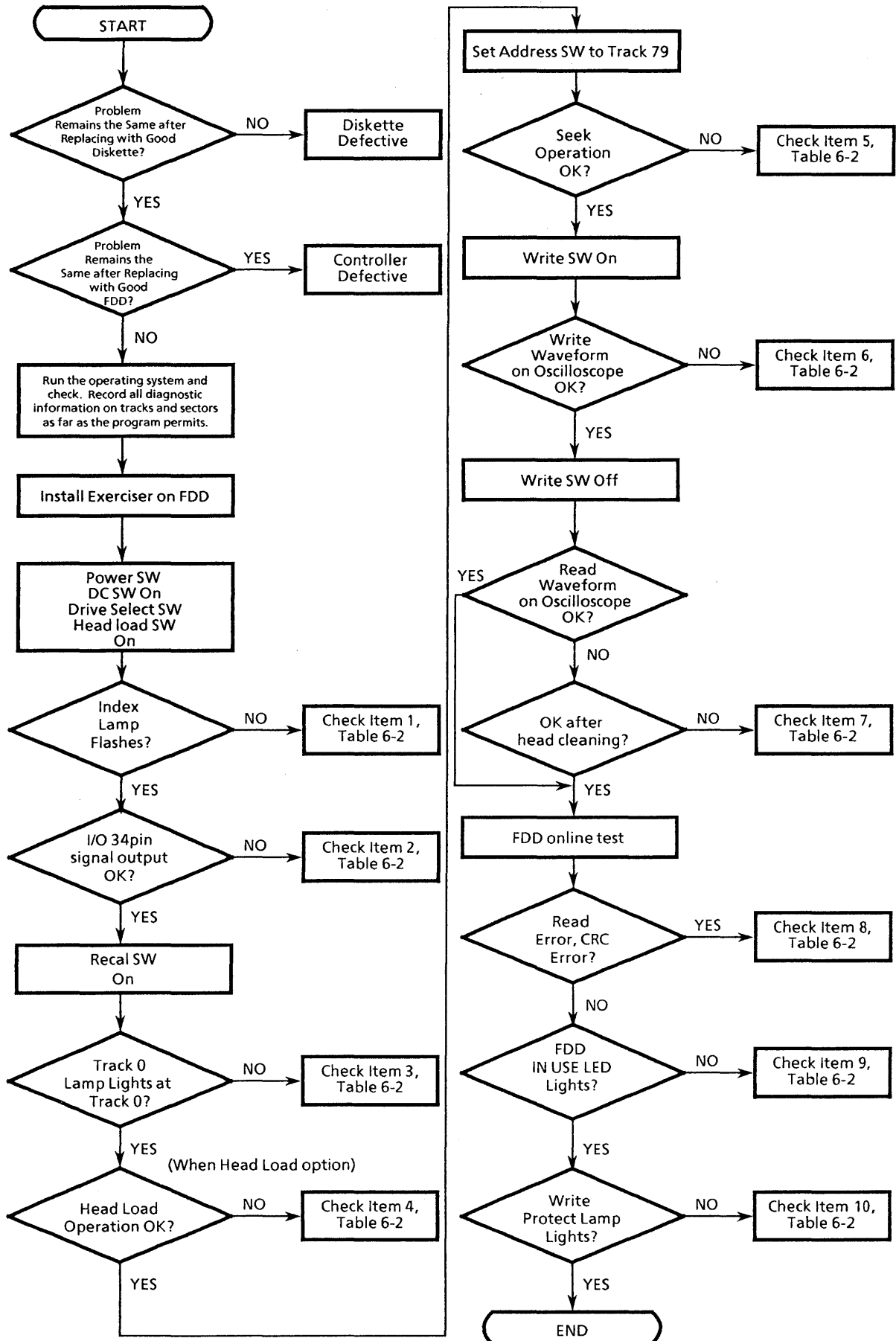

6.3 Trouble Analysis Table

Table 6-2 Trouble Analysis

Item	Trouble	No.	Cause	5.25inch
1	Index detection failure	1	Collet part faulty	Replace
		2	Drive motor control PCB	Replace
		3	Drive motor faulty	Replace
		4	Index LED faulty	Replace
		5	Index detector faulty	Replace
		6	Index LED/index detector installation faulty	Adjustable
		7	PCB motor on circuit	Repair
		8	PCB index detection circuit	Repair
2	I/O 34pin signal failure	1	See Item 1.	
		2	PCB disk change / ready / Media in / Media out ciucit	Repair
3	Track 0 detection failure	1	Track 0 assembly	Replace
		2	PCB track 0 detection failure	Repair
4	No head loading	1	See Item 1.	
		2	See Item 2.	
		3	Head load solenoid	Replace
		4	PCB head load circuit	Repair
5	No seek	1	Stepper motor	Replace
		2	Guide shaft contamination or damaged	Replace
		3	PCB stepper driver circuit	Repair
6	No write	1	See Item 1.	
		2	See Item 4.	
		3	Head disconnected	Replace
		4	Head shorted	Replace
		5	Head load bail height wrong	Adjustable
		6	PCB write circuit	Repair
7	No read	1	See Item 1.	
		2	See Item 4.	
		3	See Item 6.	
		4	PCB read circuit	Repair
8	Read error	1	See Item 1.	
		2	See Item 4.	
		3	See Item 7.	
		4	Alignment	Adjustable
		5	Azimuth	Unadjustable
		6	Index burst	Adjustable
		7	Asymmetry	Unadjustable
		8	Limiter	Unadjustable
		9	Track 0	Adjustable
		10	Head load time	Adjustable
		11	Index period	Unadjustable
		12	PCB read circuit	Repair
9	IN USE LED won't light	1	LED part	Replace
		2	PCB IN USE circuit	Repair
10	Write protect failure	1	Write protect part	Replace
		2	Write protect circuit	Repair

7. PREVENTIVE MAINTENANCE

No preventive maintenance is necessary for any FDD under normal conditions. However if adjustments are necessary, the procedures in this manual must be followed.

- Adjustments (Refer to Table 8-1)
 - (1) Make a read/write head radial adjustment at the specified track. (Sides 0, 1)
 - (2) Make an index burst adjustment at the specified track. (Sides 0, 1)
 - (3) Make an azimuth measurement at the specified track. (Sides 0, 1)

CAUTION

Do not write when using alignment diskette. Check that write protect sensor is properly operating with a data diskette.

Note: Section 9 describes the adjustment procedure in detail.

8. SPECIFICATIONS

Table 8-1 Specifications

- MINI (α) type
Drive motor is dual speed type. (300 rpm \leftrightarrow 360 rpm)

Item	Parameter	JU - 475 - 4AEG			
		MINI (α) - mode		MAXI - mode	
		TRACK	VALUE	TRACK	VALUE
1	Index period	32	$200 \pm 3.0\text{ms}$	32	$166.7 \pm 3.4\text{ms}$
2	Output level	79	180mV or more	79	180mV or more
3	Modulation	00	20% or less	00	20% or less
		79		79	
4	Resolution	79	60% or more	79	60% or more
5	Radial Alignment	32	$\pm 70\%$	—	—
6	Azimuth	68	$\pm 18'$	—	—
7	Index burst	68	$250 \pm 150\mu\text{s}$	—	—
8	Track 0	From track 0 to track 2 and back	$0.6 \times V_{cc}$ $\text{TH} \leq 5.9\text{ms}$	—	—
9	Asymmetry	79	$< 500\text{ns}$	79	$< 350\text{ns}$
10	Head load time	00	$< 50\text{ms}$	—	—
		79		—	—

- MINI (β) type
Drive motor is fixed speed type. (360 rpm)

Item	Parameter	JU - 475 - 4AGG			
		MINI (β) - mode		MAXI - mode	
		TRACK	VALUE	TRACK	VALUE
1	Index period	32	$166.7 \pm 3.4\text{ms}$	—	—
2	Output level	79	180mV or more	79	180 mV or more
3	Modulation	00	20% or less	00	20% or less
		79		79	
4	Resolution	79	60% or more	79	60% or more
5	Radial Alignment	32	$\pm 70\%$	—	—
6	Azimuth	68	$\pm 18'$	—	—
7	Index burst	68	$208 \pm 125\mu\text{s}$	—	—
8	Track 0	From track 0 to track 2 and back	$0.6 \times V_{cc}$ $\text{TH} \leq 5.9\text{ms}$	—	—
9	Asymmetry	79	$< 500\text{ns}$	79	$< 350\text{ns}$
10	Head load time	00	$< 50\text{ms}$	—	—
		79		—	—

9. ADJUSTMENTS AND VERIFICATIONS

9.1 Motor Speed Verification (Index Period)

- (1) Insert a diskette, run the motor, and clamp. Refer to the index period column of Table 8-1.
- (2) Step to the specified track.
- (3) Connect a frequency counter to the INDEX signal: TP7
- (4) Check that the frequency counter readings meet the specifications of Table 8-1.

9.2 Write Protect Verification

- (1) Check that the exerciser's write protect lamp goes on and off as a diskette is inserted and removed as specified in the table below.

Diskette with write protect hole open	Diskette with write protect hole closed
OFF	ON

(Not write protected)

(write protected)

9.3 Head Output Verification

Use a new diskette if possible to identify head failure for this check.

- (1) Insert a good diskette.
- (2) Run the motor.
- (3) Step to the track specified in the output level column of Table 8-1.
- (4) Connect the oscilloscope probe as specified below.

CH1	CH2	EXT
TP1	TP2	TP7

Invert channel 2 and select the Add mode.

Set vertical deflection to 10 mV/division and horizontal deflection to 20 ms/division.

- (5) Write 2F (all "1"s) on the entire circumference.
- (6) Check that the average output level meets the specifications of Table 8-1.

$$V_{\text{average}} = \frac{V_{\text{max}} + V_{\text{min}}}{2}$$

If it does not meet the specifications, refer to Item 7 of the Trouble Analysis Table.

9.4 Output Modulation Verification

Modulation is calculated by the following formula.

$$\text{Modulation} = \frac{V_{\max} - V_{\min}}{V_{\max} + V_{\min}} \times 100 (\%)$$

Using the value obtained in section 9.3, and check that the calculated value meets the specifications of Table 8.1.

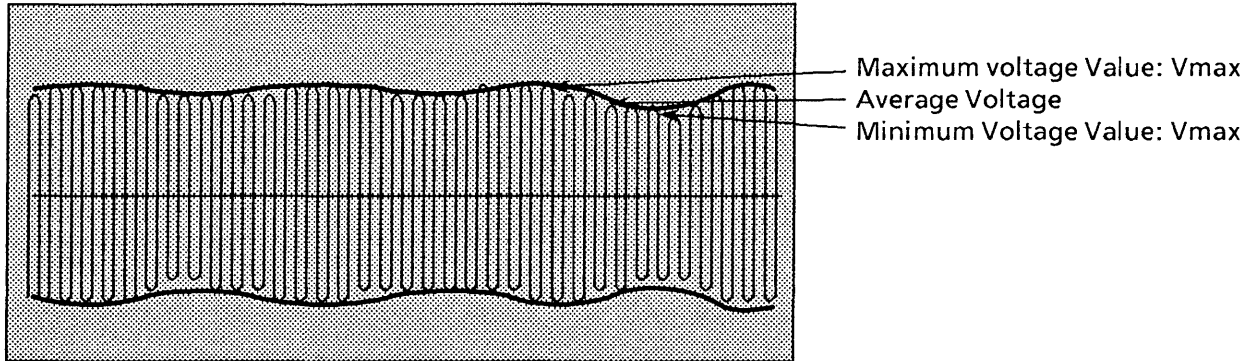

Fig. 9-1 Modulation

9.5 Resolution Verification

- (1) Leave the oscilloscope in the same condition as mentioned in section 9.3.
- (2) Resolution is calculated by the following formula.

$$\text{Resolution} = \frac{V_{2F \text{ average}}}{V_{1F \text{ average}}} \times 100 (\%)$$

- (3) Check that the calculated value meets the specifications of Table 8-1.

9.6 Radial Alignment Verification and Adjustment

Introduction

This adjustment is normally not necessary.

If the mounting screws for the stepper motor loosen, or if parts become defective, or if a compatibility error occurs, check and readjust according to the following procedure.

Steps(4) to (9) below should be performed regardless of the type, CE or DAD alignment diskette used. Use an alignment diskette suitable to the type of FDD to be adjusted according to Table 3-1.

- (1) Insert Panasonic alignment diskette.

CAUTION:

Be sure to leave the alignment diskette under room conditions for 20 minutes before adjustment.

- (2) Step to the track specified in the radial alignment column of Table 8-1.
- (3) Leave the oscilloscope in the same condition as mentioned in section 9.3.
- Cats Eye System
- (4) Check the output waveforms for sides 0 and 1. They should appear as in Fig. 9-2.
- (5) The two waveforms should appear in the amplitude ratio in the radial alignment column of Table 8-1 or better.
- (6) If the specified ratio is not satisfied, loosen the two mounting screws for the stepper motor.

- (7) Move the stepper motor along the base by hand until the two waveforms assume approximately the same amplitude, and retighten the mounting screws. (See Fig. 9-2.)
- (8) Step the head outward (track 0) and inward (track 79), and confirm that the adjustment has been completed.
- (9) After the radial adjustment, be sure to confirm track 0 sensor adjustment as described in section 9-9.

Note: Alignments on sides 0 and 1 are adjusted at the factory. If they are misaligned, adjust them to meet the specifications of Table 8-1.

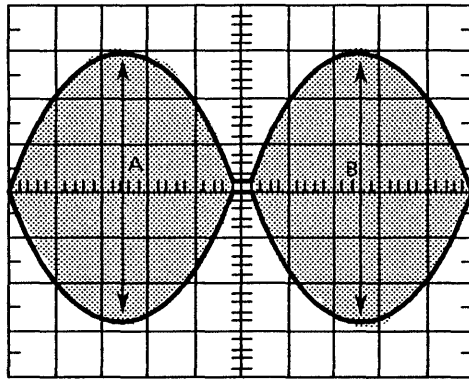

when $A > B$

$$\frac{B}{A} \times 100 (\%)$$

when $A < B$

$$\frac{A}{B} \times 100 (\%)$$

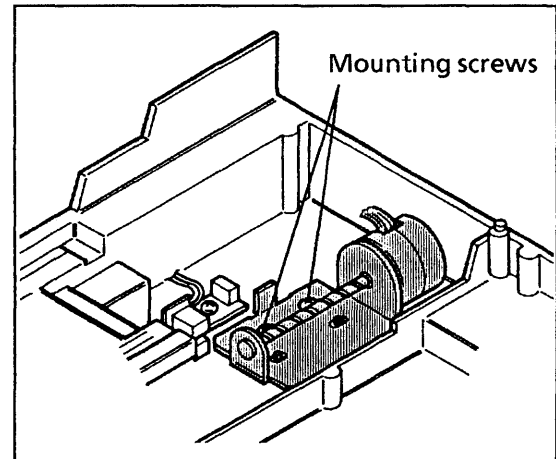

Fig. 9-2 Radial Alignment Waveforms (CATS EYE)

Fig. 9-2-1 Stepper Motor Mounting Screws

9.7 Azimuth Verification

- (1) Insert an alignment diskette. Seek to the track specified in the azimuth column of Table 8-1.
- (2) Set the oscilloscope in the same conditions as in section 9.3, and set horizontal deflection to 0.5 ms/division.
- (3) Measure as shown below.
- (4) Confirm that the measured value meets the specifications in the azimuth column of Table 8-1.

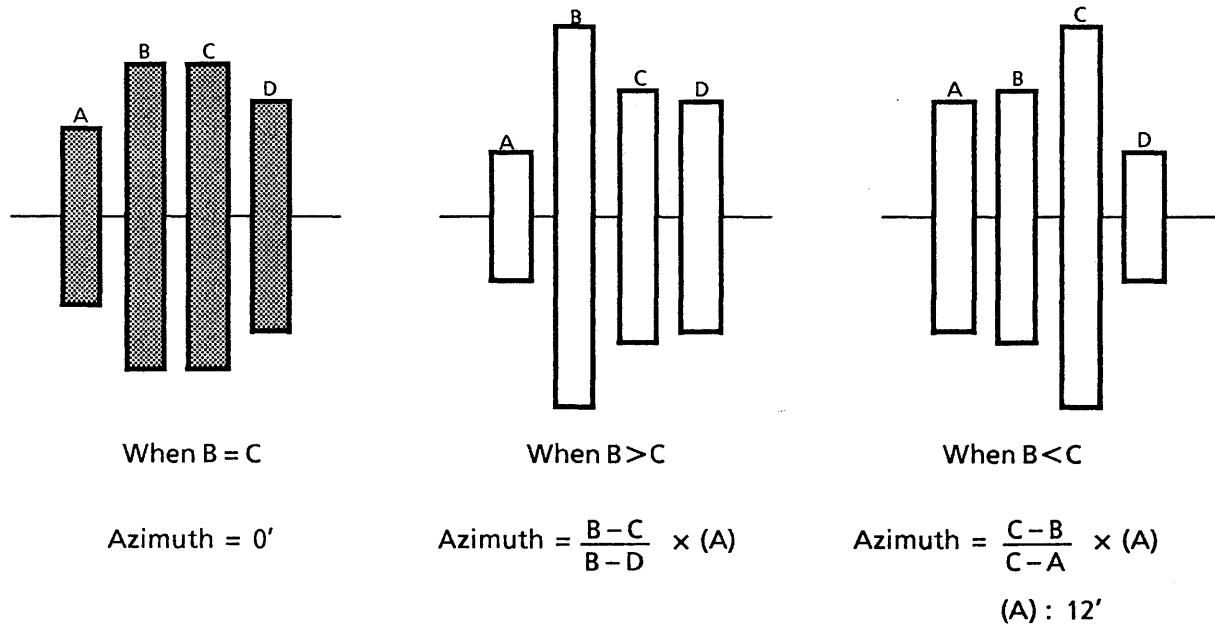

Fig. 9-4 Azimuth Waveforms

9.8 Index Burst Verification and Adjustment

- (1) Insert an alignment diskette. Seek to the track specified in the index burst column of Table 8-1.
- (2) Set the oscilloscope in the same conditions as in section 9.7, and set horizontal deflection to $50\mu\text{s}/\text{division}$.
- (3) Check that the time from oscilloscope start to the first data meets the index burst specifications of Table 8-1.
- (4) If the specifications are not met, adjust as follows.
 - Loosen the index detector mounting screws enough to free the assembly.
 - Adjust the timing to meet the specifications of Table 8-1.
 - Retighten the screw.
 - Check the timing again.

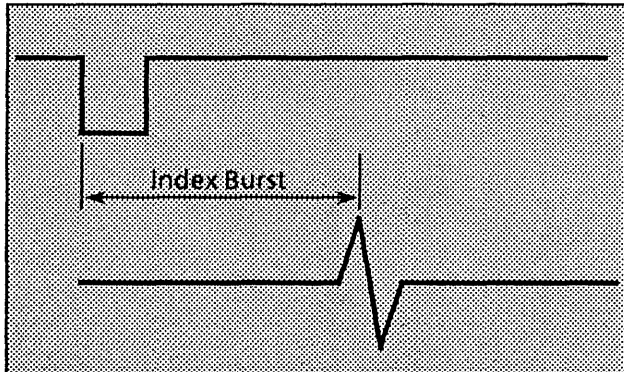

Fig. 9-5 Index Timing

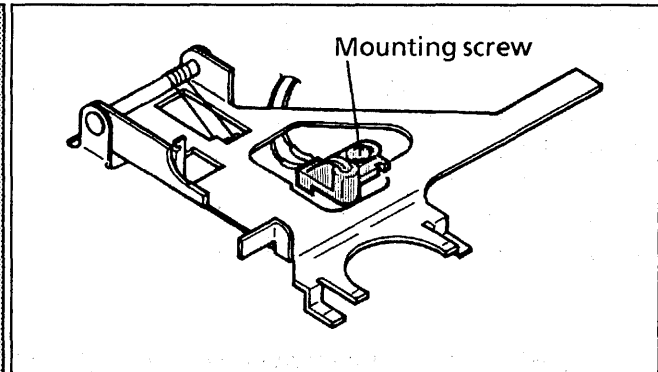

Fig. 9-5-1 Index Detector

9.9 Track 0 Sensor Adjustment

- (1) Set the oscilloscope as follows.

TRIG	SYNC	CH1	CH2	VERT	HORIZ
INT	TP12	TP12	TP 8	0.2V	1 ms

- (2) Step between specified tracks at in the track 0 item of Table 8-1. (Turn the seek delay switch on the exerciser to adjust 3 ms seek.)
- (3) Loosen the track 0 sensor screw and adjust until the waveform on the oscilloscope appears as shown in Fig. 9-6.

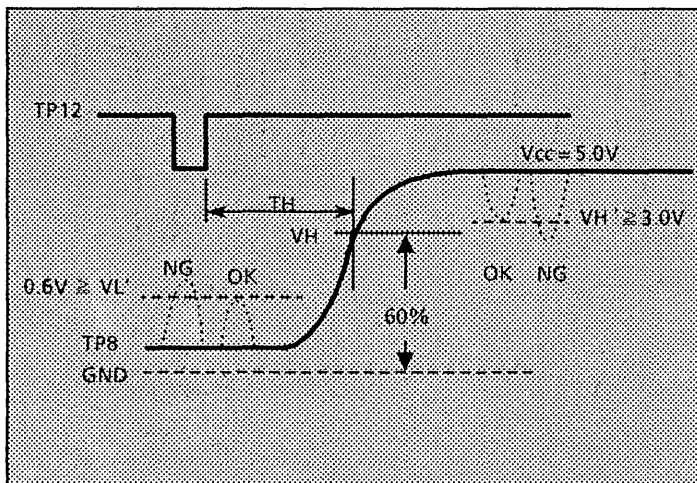

Fig. 9-6 Track 0 Waveform

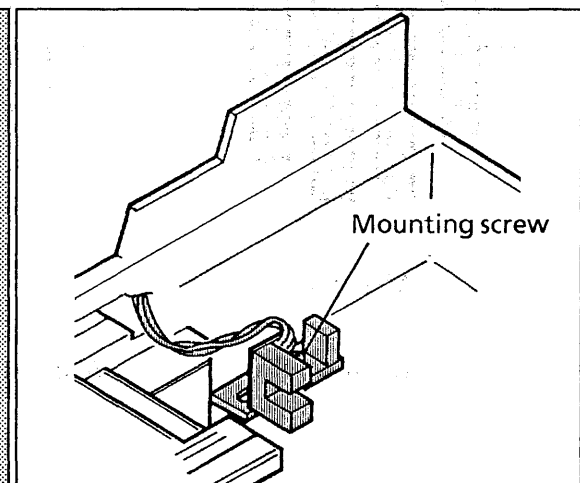

Fig. 9-6-1 Track 0 Adjustment

9.10 Asymmetry Verification

- (1) Insert a work diskette.
- (2) Step to the track specified in the asymmetry item of Table 8-1.
- (3) Set the oscilloscope as follows.

TRIG	SYNC	CH 1	CH 2	VERT	HORIZ
INT	TP 6	TP 6	TP 1	0.1 V	1 μ S

- (4) Write 1F.
- (5) A read waveform is displayed on the oscilloscope as shown in Fig. 9-7.
- (6) Confirm if it satisfies the value as shown in Fig. 8-1.

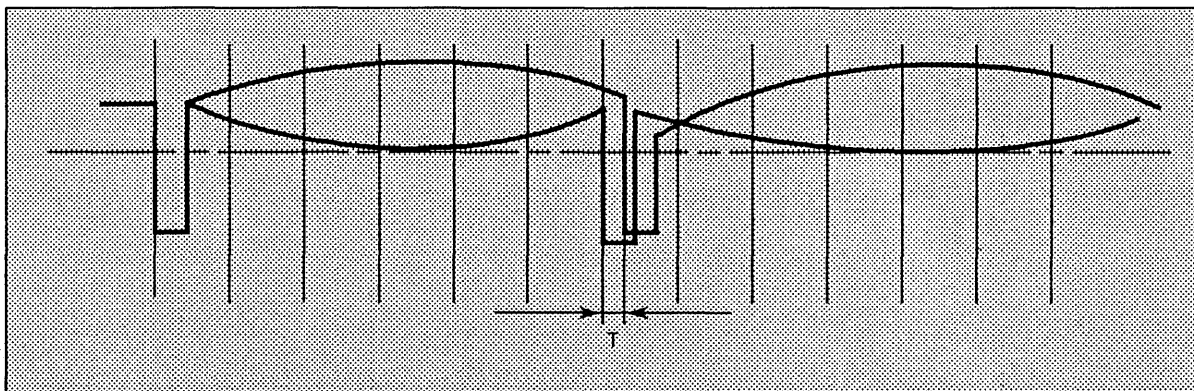
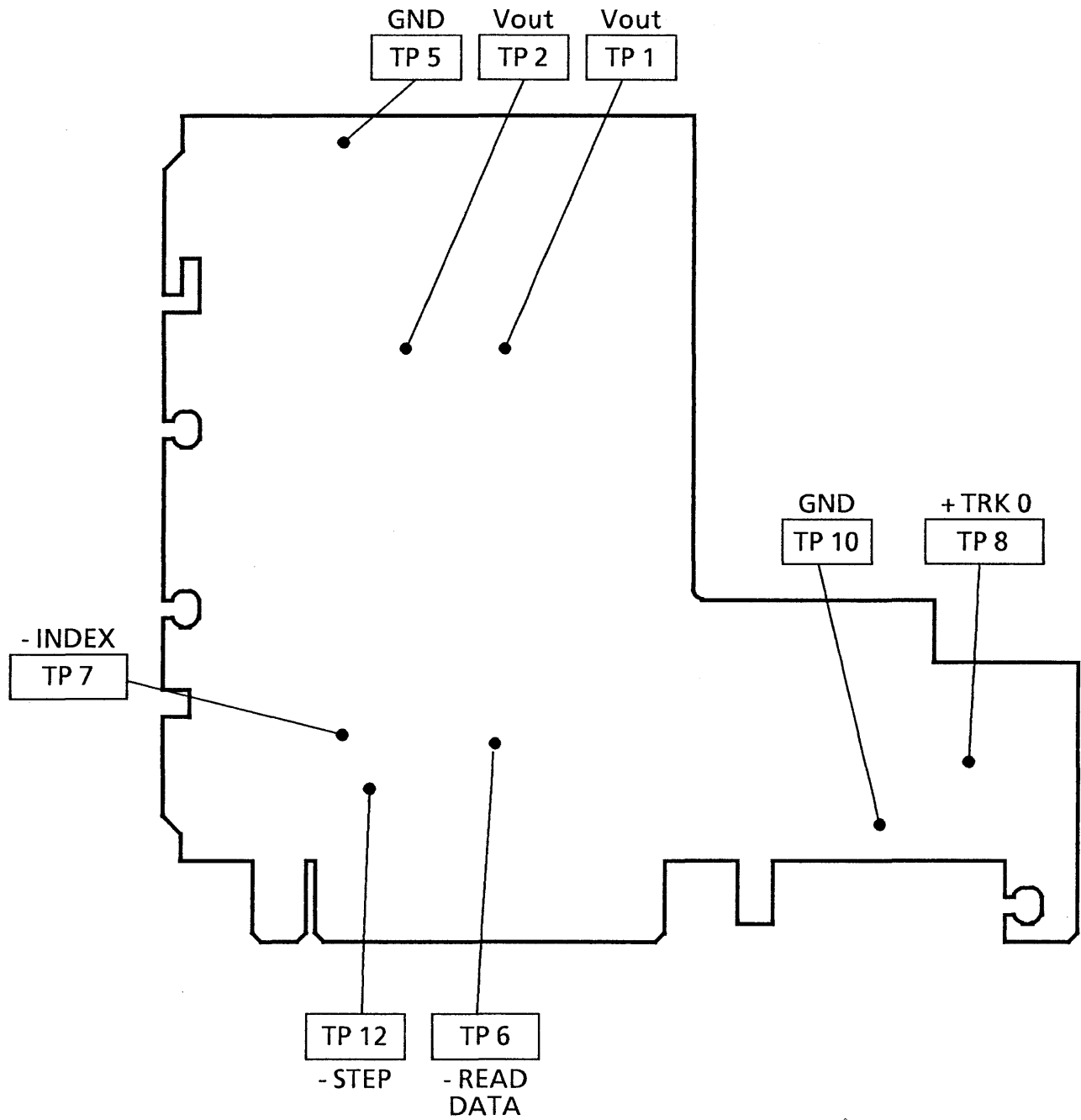

Fig. 9-7 Asymmetry Waveform

10. TEST POINTS

Printed Circuit Board
(Top View)



11. PANASONIC ALIGNMENT DISKETTE

Table 10-1 Panasonic Alignment Diskette

TPI	Part No.	Index Burst	Azimuth	Radial Alignment	Model
48	817-128	34 TRK	34 TRK	16 TRK	JA-551 JU-455
96	817-560	68TRK	68TRK	32TRK	JA-561 JU-465 JU-595 JU-475

PART. II

12. REMOVALS AND INSTALLATIONS

12.1 PCB Removal and Installation

- (1) Remove the four shield plate mounting screws and take out the shield plate.
- (2) Remove the one PCB mounting screw.
- (3) Disconnect the connectors (J3 CON, J4 CON, J5 CON, J7 CON, J8 CON) from the PCB.
- (4) To reinstall, reverse the above procedure.
- (5) Readjustment is not necessary after PCB replacement.

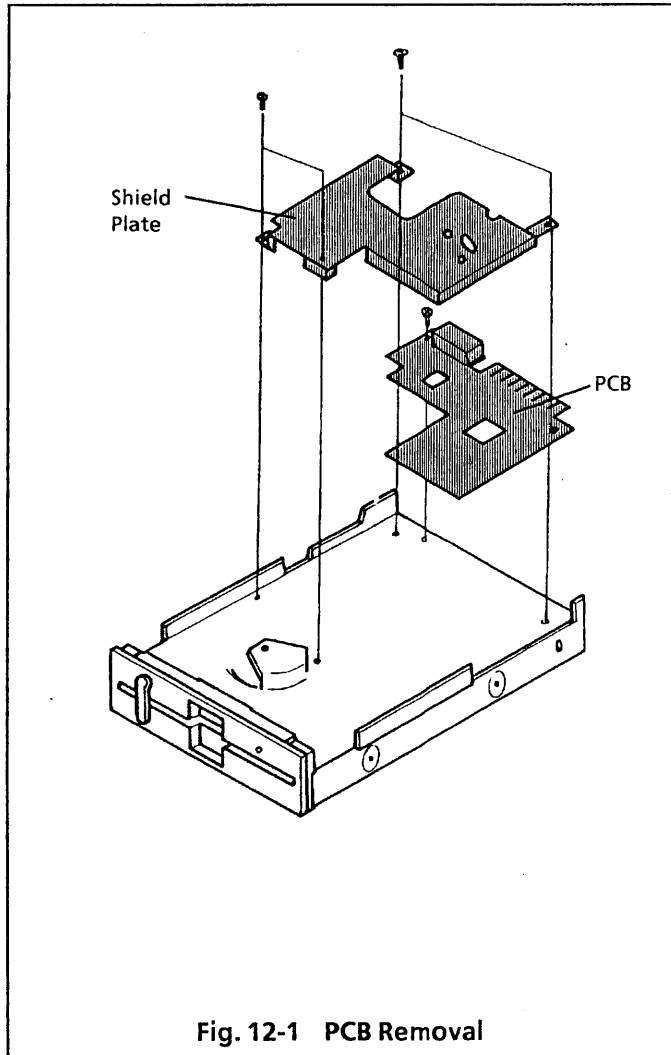

Caution of the cable leading

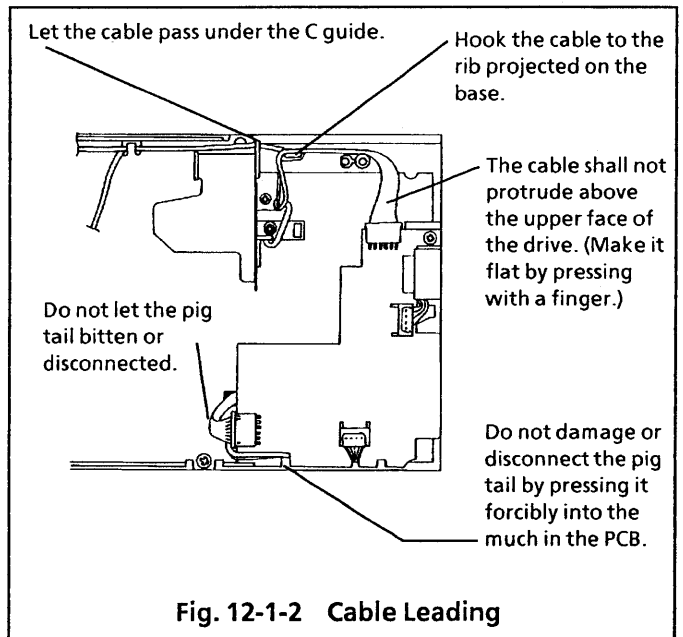

12.2 Front Plate and Handle Removal and Installation

- (1) Operate the lock cam of the clamp assembly, and turn the clamp handle in the direction of clamping.
- (2) Remove the clamp handle.
- (3) Remove the two front plate mounting screws, and take off the front plate.
- (4) Reverse the above procedure to reinstall.

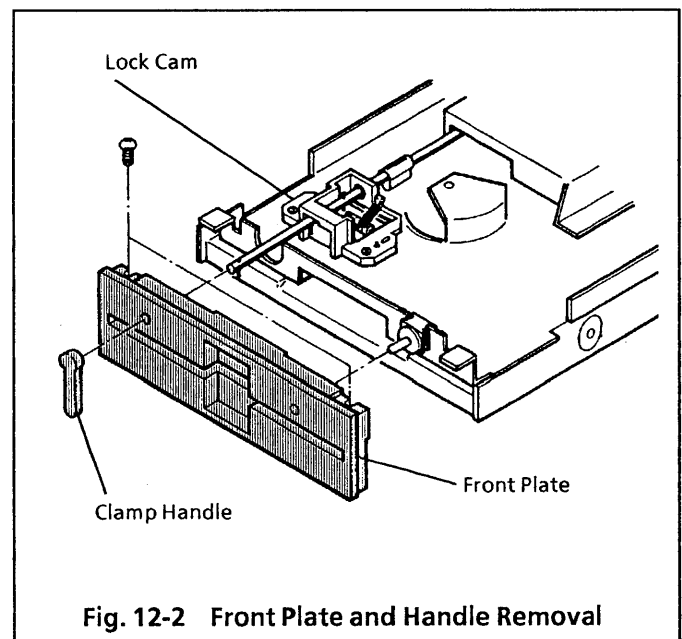

12.3 Track 0 Sensor Assembly Removal and Installation

- (1) Remove the shield plate as described in section 12.1 step (1).
- (2) Disconnect the J3 connector from PCB.
- (3) Draw out the pins the track 0 sensor assembly from the following locations on the J3 connector : No2, 4, 6.
At that time, draw out the pins with lifting the stopper on the connector.
- (4) Remove the track 0 sensor assembly mounting screw and take out the track 0 sensor assembly.
- (5) Reverse the above procedure to reinstall.
- (6) After reinstallation, adjust the track 0 sensor as described in section 9.9.

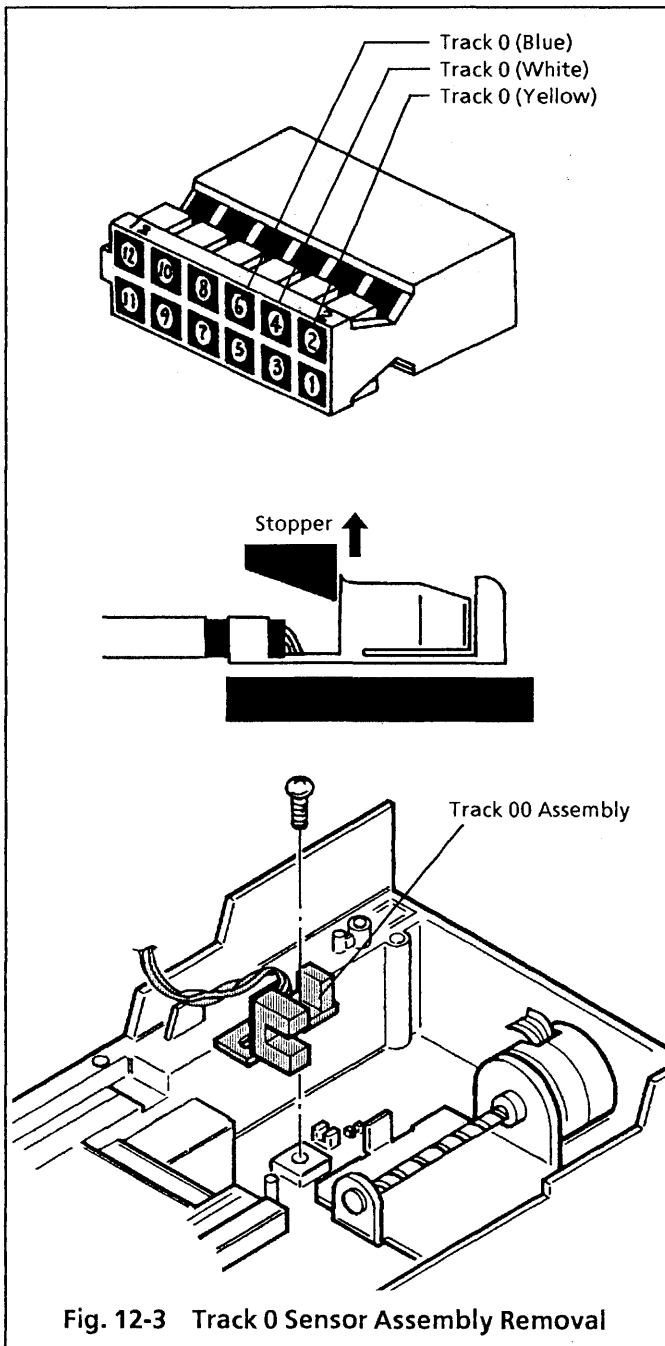

Fig. 12-3 Track 0 Sensor Assembly Removal

12.4 Collet Assembly Removal, Installation and Adjustment

- (1) Remove the cartridge guide assembly as described in section 12.7.
- (2) Remove the lifter unit as described in section 12.12
- (3) Remove the collet assembly from the guide shaft.
- (4) Reverse the above procedure to reinstall.
- (5) After reinstallation, perform collet assembly center adjustment.
- (6) Collet assembly center adjustment.
 - a) Temporarily fasten the cartridge guide assembly.
 - b) Insert a diskette or dummy diskette and clamp it.
 - c) Clamp repeatedly a few times to find a good fit between the collet and the inside diameter of the drive motor.
 - d) Bind the screws of the cartridge guide.
 - e) Check step c) again, if not good repeat step a) through d) until the correct center adjustment is achieved.

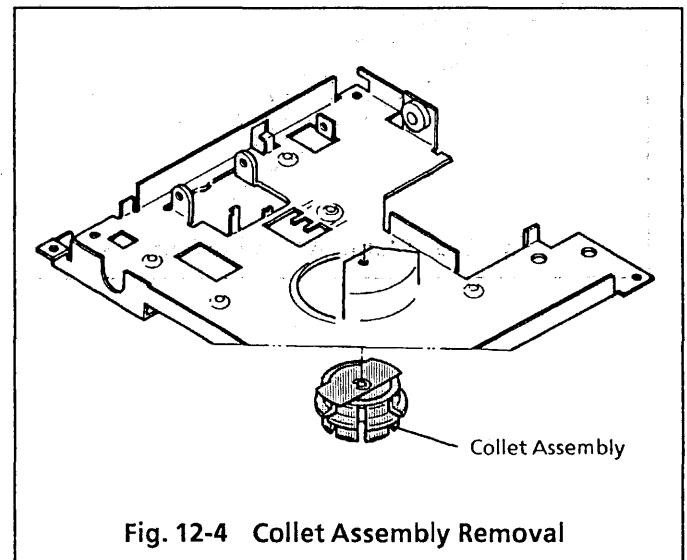

Fig. 12-4 Collet Assembly Removal

12.5 Clamp Assembly Removal and Installation

- (1) Remove the front plate as described in section 12.2.
- (2) Remove the shield plate as described in section 12.1 step (1).
- (3) Remove the two clamp assembly mounting screws and take out the clamp assembly.
- (4) Reverse the above procedure to reinstall.

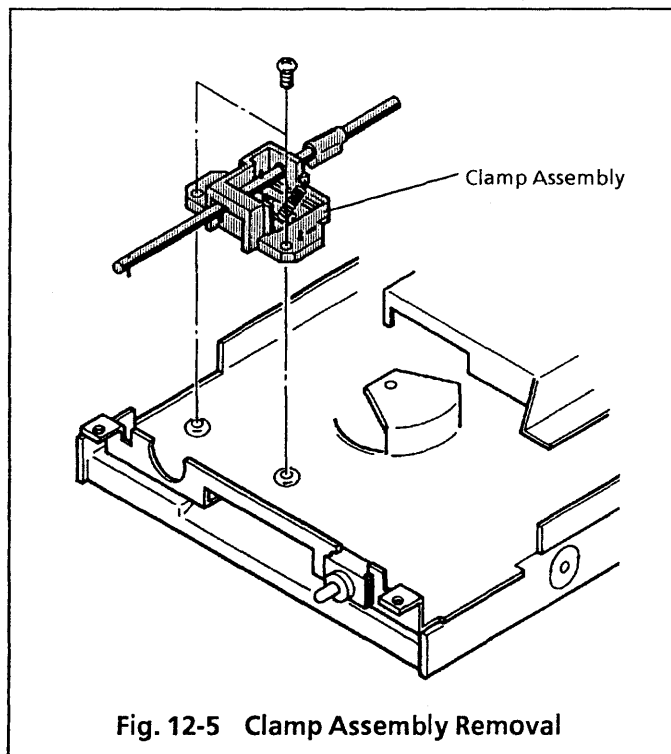
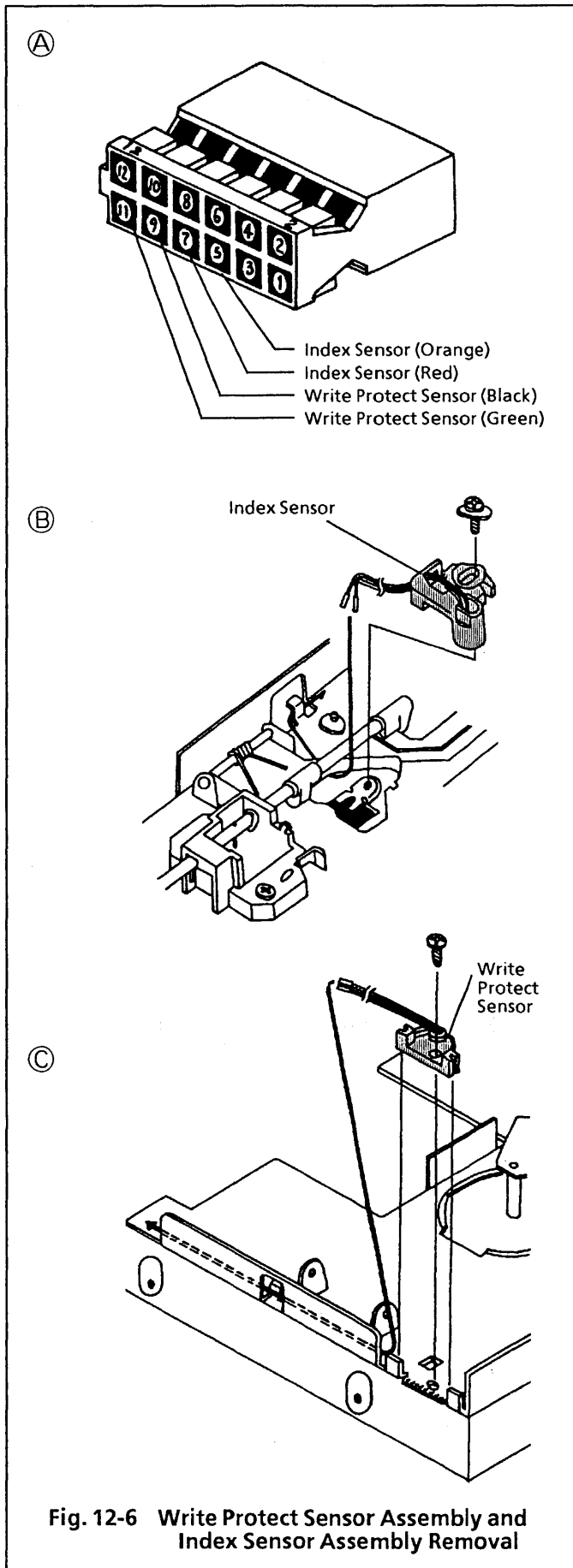

Fig. 12-5 Clamp Assembly Removal

12.6 Write Protect Sensor Assembly and Index Sensor Assembly Removal and Installation

- (1) Remove the shield plate as described in section 12.1 step (1).
- (2) Disconnect the J3 connector from PCB.
- (3) Draw out the pins of the write protect sensor assembly from the following locations on the J3 connector : No9, 11.
At that time, draw out the pins with lifting the stopper on the connector.
- (4) Draw out the pins of the index sensor assembly from the following locations on the J3 connector : No5, 7.
At that time, draw out the pins with lifting the stopper on the connector.
- (5) Remove the write protect sensor mounting screw and index sensor mounting screw respectively.
- (6) Reverse the above procedure to reinstall.
- (7) When reinstalling the write protect sensor, exercise care so that the leads and write protect sensor will not project from the bottom and side of the base.
- (8) After index sensor installation, adjust the index burst as described in section 9.8.



12.7 Cartridge Guide Assembly Removal and Installation

- (1) Remove the PCB as described in section 12.1.
- (2) Remove the handle and front plate as described in section 12.2.
- (3) Remove the clamp assembly as described in section 12.5.
- (4) Remove the write protect sensor mounting screw.
- (5) Remove the three cartridge guide mounting screws and take out the cartridge guide assembly.
- (6) After reinstallation, adjust the collet assembly as in section 12.4 step (6) and adjust the index burst as in section 9.8.
- (7) When removing or reinstalling, be careful not to damage the carriage arm with the lifter.

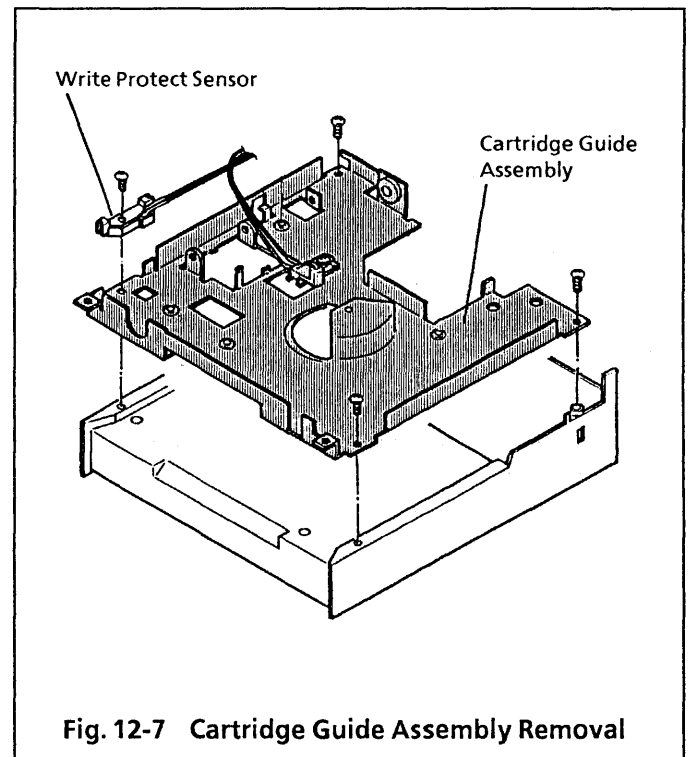

12.8 Stepper Motor Assembly Removal and Installation

- (1) Remove the head carriage assembly as described in section 12.9.
- (2) Remove the two stepper motor assembly mounting screws.
- (3) Remove the stepper motor and stepper motor stopper.
- (4) Reverse the above procedure to reinstallation.
- (5) After reinstallation, adjust the radial alignment and track 0 sensor as described in section 9.6 and 9.9.

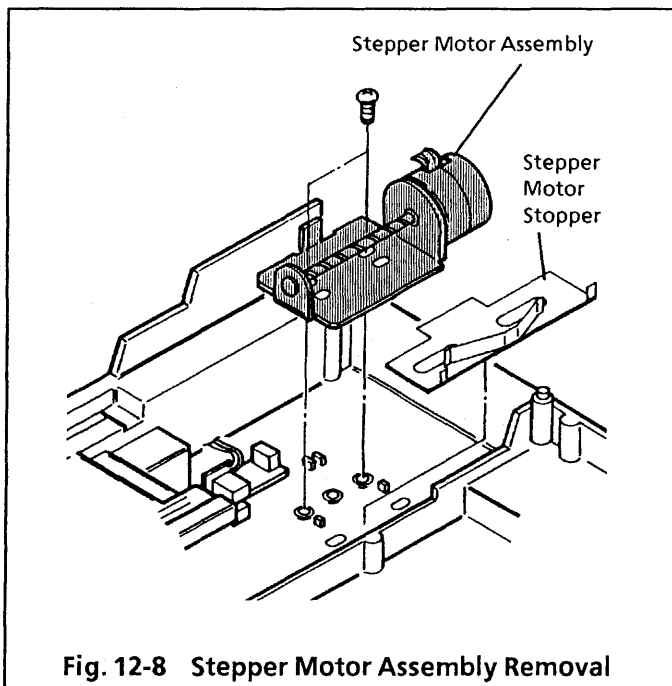

12.9 Head Carriage Assembly Removal and Installation

- (1) Remove the PCB as described in section 12.1.
- (2) Remove the one pig tail clamp mounting screw.
- (3) Remove the two guide rod clamp mounting screws.
- (4) Remove the head carriage assembly, guide rod clamp, guide rod, and pig tail clamp.
- (5) Pull out the guide rod from the head carriage assembly.
- (6) Reverse the above procedure to reinstall.
- (7) After reinstallation, adjust the radial alignment and track 0 sensor as described in section 9.6 and 9.9.

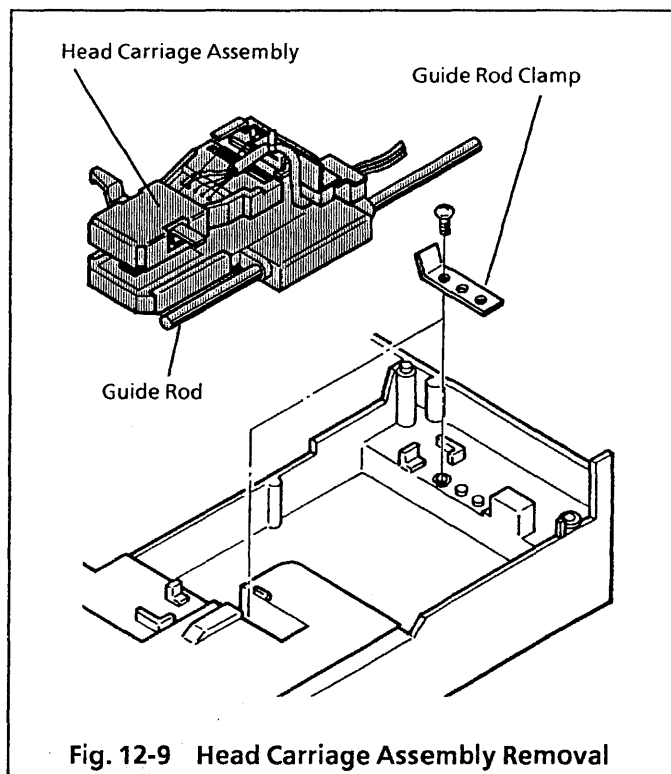

Pig tail leading

- (1) Pass the pig tail through the pig tail clamp.
(See Fig. 12-9-1.)
- (2) Locate the side 0 to the outer side and side 1 to the inner side, provide a clearance of 1mm between them, and place them parallel to each other.
(Avoid twisting or closing.)
- (3) Fig. 12-9-2
[When the carriage is on the outer-most track]
 - (a) When the head carriage is on the outer-most track, lead the side 0 and side 1 along line A on the pig tail clamp.
 - (b) Ensure that the pig tail does not come in contact with the inner wall of the base.
(Contacting of the pig tail is allowable if the side 0 and side 1 are not overlapped each other vertically.)
- (4) Fig. 12-9-2
[When the carriage is on the inner-most track]
 - (a) When the head carriage is on the inner-most track, lead the side 0 and side 1 along line B on the pig tail clamp.
- (5) Provide a clearance of about 1mm between the side 0 and side 1.
- (6) Ensure that there is not excessive load or protrusion at the outlet for the pig tail in the head carriage.
- (7) Fasten the pig tail clamp with screw.
- (8) Do not pull the pig tail by a force more than 500g after it has been clamped.
- (9) Pull the pig tail lightly to ensure that it does not move.

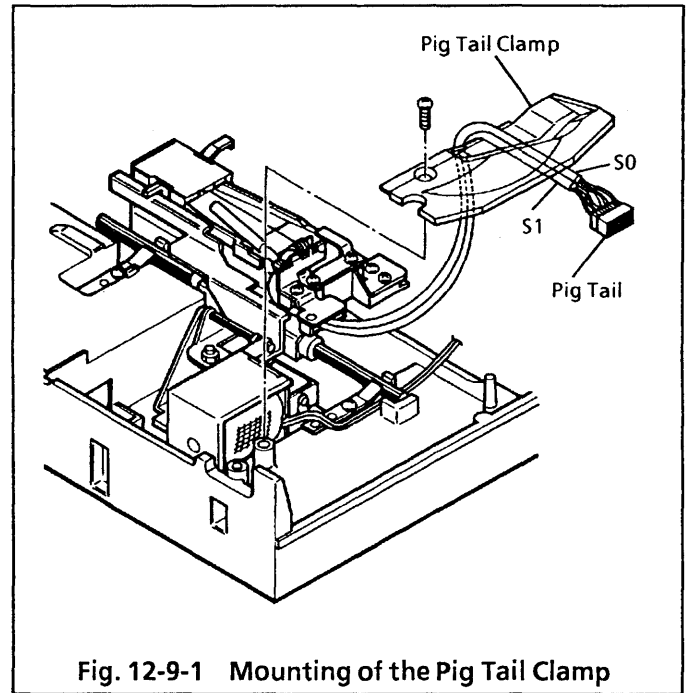
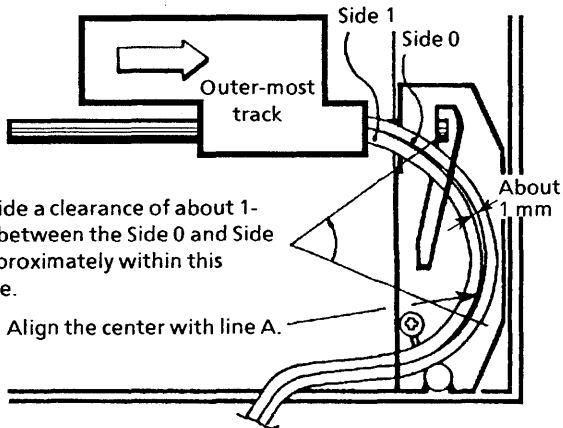

Fig. 12-9-1 Mounting of the Pig Tail Clamp

When the carriage is on an outer-most track :



When the carriage is on an inner-most track :

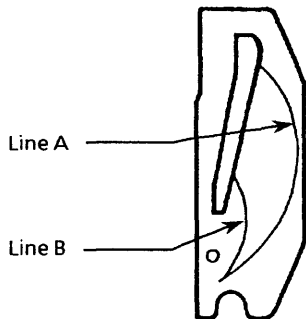
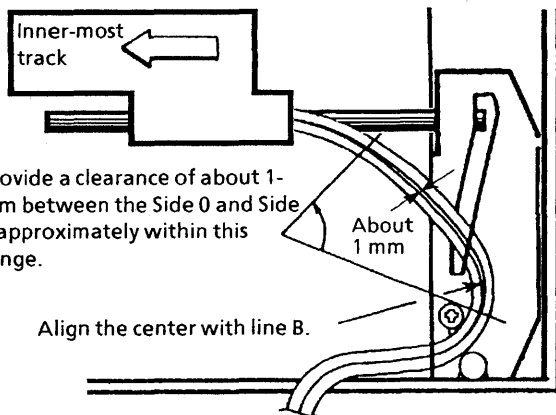

Fig. 12-9-2 Pail Tail Leading

12.10 Drive Motor Removal and Installation

- (1) Remove the carriage guide assembly as described in section 12.7.
- (2) Remove the three drive motor mounting screws and take off the drive motor from the base.
- (3) Reverse the above procedure to reinstall.
- (4) After reinstallation, the adjustments necessary upon reinstallation of the carriage guide as described in section 12.7.

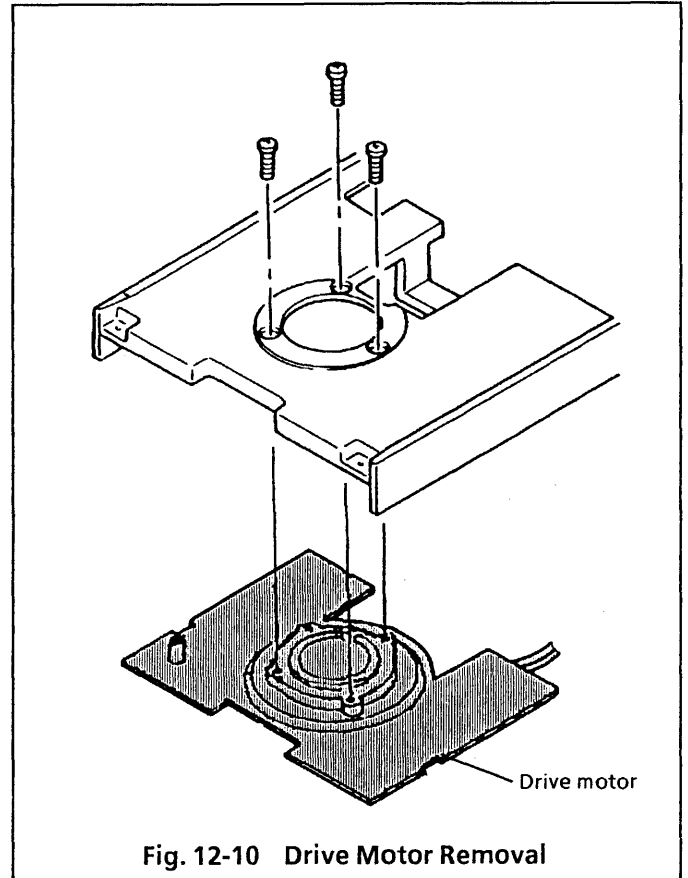
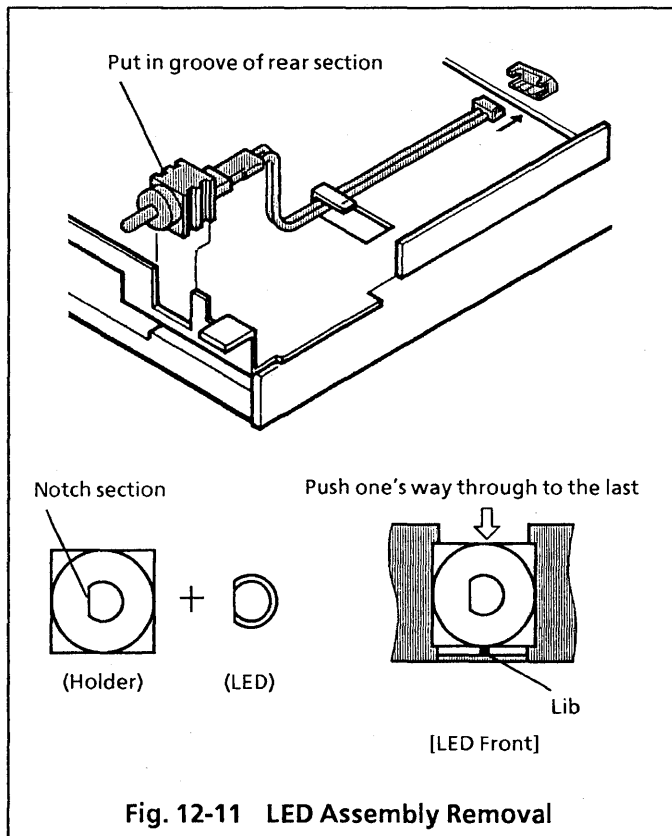

Fig. 12-10 Drive Motor Removal

12.11 LED Assembly Removal and Installation

- (1) Remove the clamp handle and front plate as described in section 12.2.
- (2) Disconnect the J8 connector from PCB.
- (3) Remove the LED assembly by sliding it slant from the cartridge guide assembly.
- (4) Reverse the above procedure to reinstall.
- (5) The LED can be removed and installed as it is.



12.12 Lifter Unit Removal and Installation

- (1) Remove the clamp assembly as described in section 12.5.
- (2) Remove the lifter shaft clamping retaining ring and draw out the lifter shaft.
- (3) Remove the lifter unit.
- (4) Reverse the above procedure to reinstall.

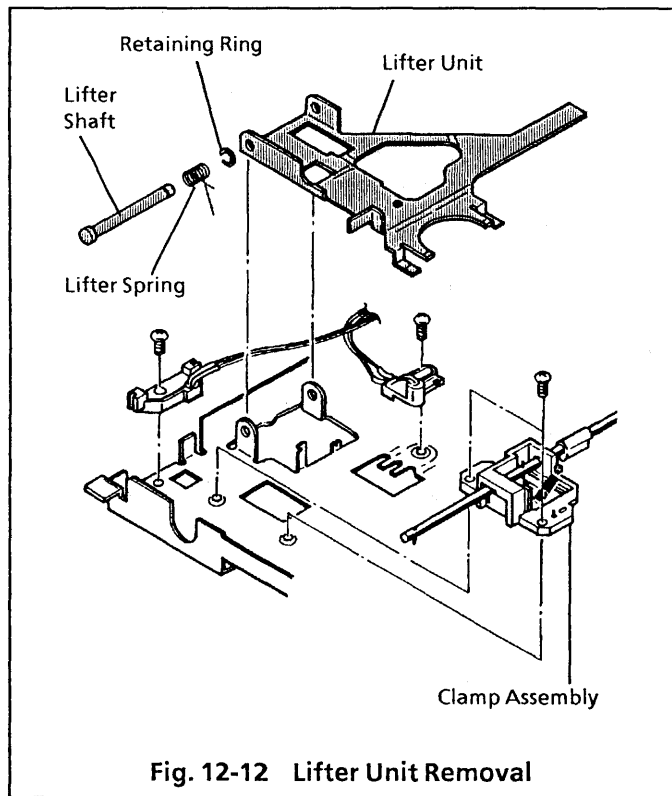

12.13 Media Lifter Removal and Installation

- (1) Remove the clamp assembly as described in section 12.5.
- (2) Remove the lifter shaft clamping retaining ring draw out the lifter shaft.
- (3) Remove the media lifter.
- (4) Reverse the above procedure to reinstall.

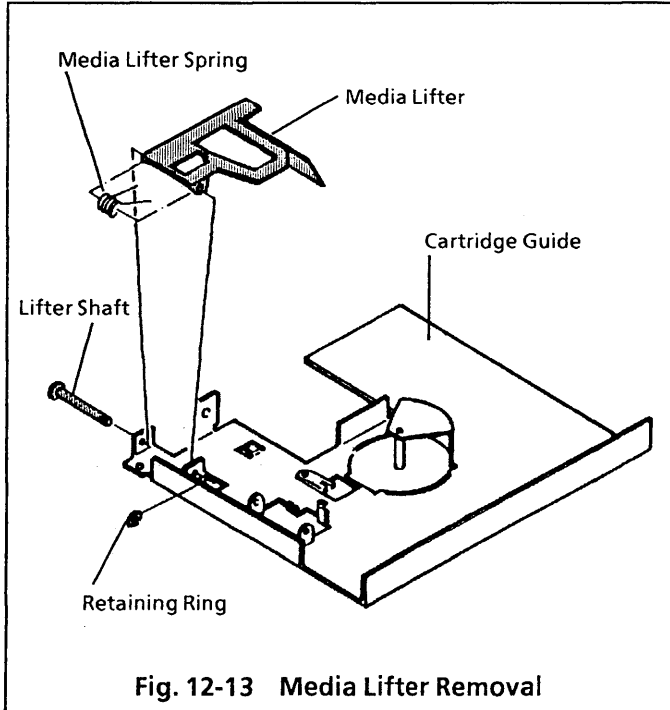

12.14 Media Sensor Assembly Removal and Installation

- (1) Remove the PCB as described in section 12.1.
- (2) Remove the cartridge guide assembly as described in section 12.7.
- (3) Draw out the pins of the media sensor assembly from the following locations on the J3 connector : No8, 10, 12.
At that time, draw out the pins with lifting the stopper on the connector.
- (4) Remove the media sensor assembly mounting screw and take out the media sensor assembly.
- (5) Reverse the above procedure to reinstall.

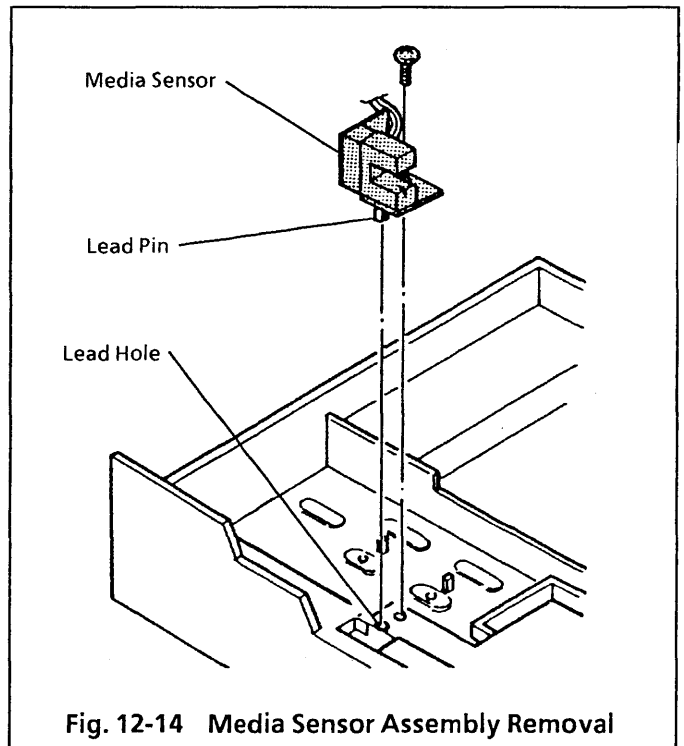

13. EXPLODED VIEW [JU-475-4AGG]

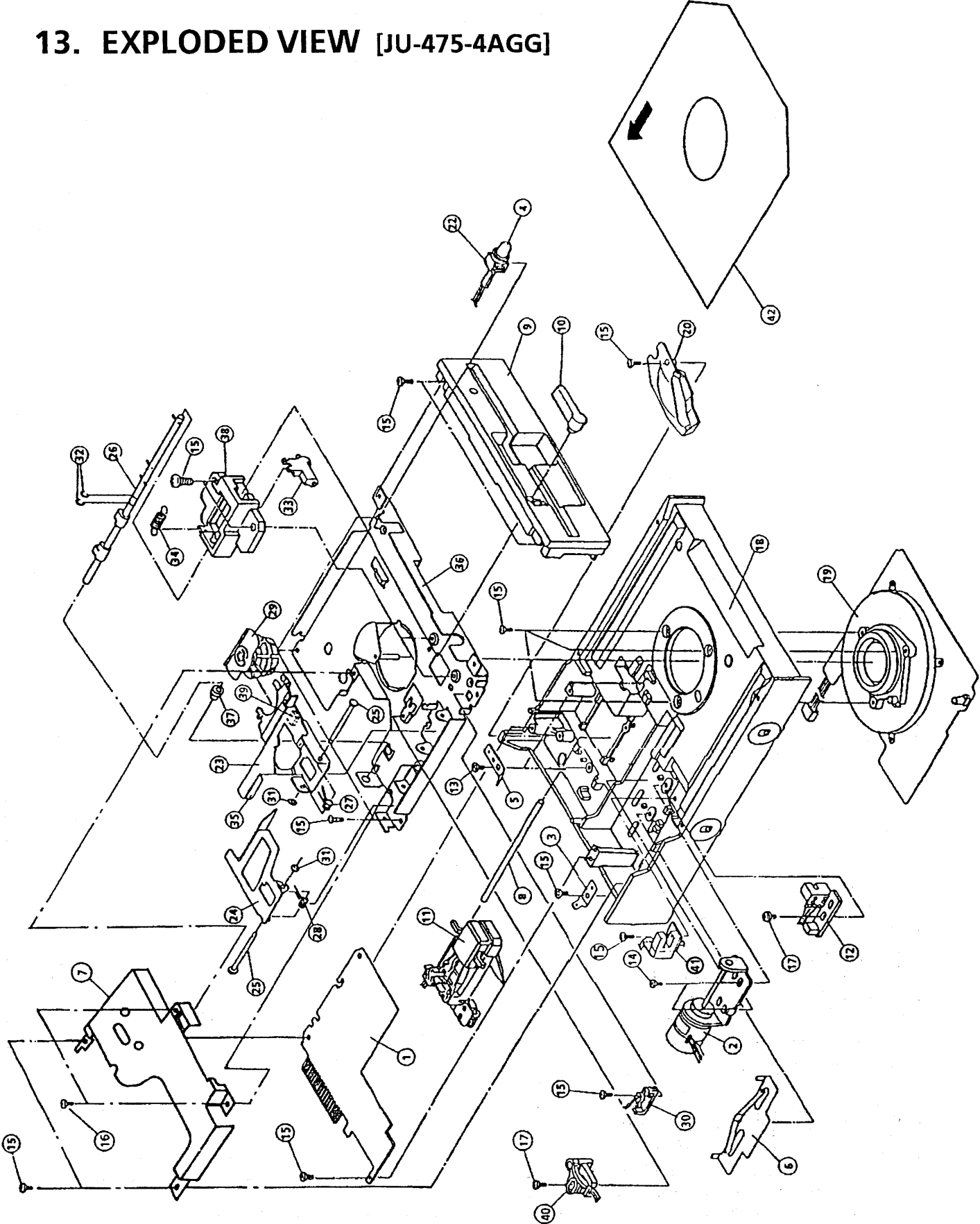

* Caution : For transportation, insert the dummy diskette in the drive unit and close the lever. Remove the dummy diskette before use of the drive unit.

14. REPLACEMENT PARTS LIST

MODEL : JU - 475 - 4AGG

Ref. No.	Part No.	Part Name & Description	Pcs	*RSP	Remarks
1	YTUF47PK4	PCB Assembly	1		NLA
2	YTFMD02700B4	Stepper Motor	1	2	
3	YTFJC00521B4	Faston	1		
4	LN41YPHL	LED	1	2	
5	YTF2C07161B4	Clamp (For Guide Rod)	2		
6	YTF2C08722B3	Stepper Motor Stopper	1		
7	YTF2H12862B2	Shield Plate	1		
8	YTF4H03091B4	Guide Rod	1		
9	YTF5W03272B2	Front Panel	1	3	
10	YTF6A01092B3	Clamp Handle	1	3	
11	YTUF47HD4-T	Head Carriage Assembly [YTUF47HD4-M]	1	2	
12	YTUF45TRK8	Track 0 Assembly	1	2	
13	XSB3 + 4FX	Screw (For Guide Rod Clamp)	2		
14	XSB3 + 5FX	Screw (For Stepper Motor)	2		
15	XSB3 + 6FX	Screw [PCB Assembly (1), Faston (1), Front Plate (2), Drive Motor (3), Pig Tail Clamp (1), Shield Plate (2), Cartridge Guide (4), Clamp Bearing A (2), Media Sensor (1)]	17		
16	YTF1E00310B4	Screw (For Shield Plate)	2		
17	YTF1E00300B4	Screw (For Track 0 Sensor, Index Sensor)	2		
18	YTF3L12930B2	Base	1		
19	YTUF5DMT-3BT	Drive Motor [FMD01732B4T]	1	2	
20	YTF1G01482B3	Pig Tail Clamp	1		
22	YTF7K14480B4	LED Holder Assembly	1		
23	YTF3C07194B3	Lifter	1		
24	YTF3C10760B3	Media Lifter	1		
25	YTF4H01360B4	Lift Shaft	2		
26	YTF4H03109B3	Clamp Cam Assembly	1		
27	YTF4J01901B4	Lift Spring	1		
28	YTF4J03500B4	Media Lift Spring	1		
29	YTUF52CLT	Collet Assembly	1	2	
30	YTUF45WP8	Write Protect Sensor	1	2	
31	XUC2	Retaining Ring	2		
32	XUC3	Retaining Ring	2		
33	333D36817693	Lock Cam	1		
34	333D46624770	Lock Spring	1		
35	333D46817500	Pad A	1		
36	YTF2E12870B1	Cartridge Guide	1		
37	YTF4F03424B4	Clamp Bearing B	1		
38	YTF4F03435B2	Clamp Bearing A	1		
39	YTF2F12940B4	Pad B	1		
40	YTUF45IDX8	Index Sensor	1	2	
41	YTUF47MS4	Media Sensor	1	2	
42	YTF8C02302B4	Dummy Diskette	1		

*RSP : Recommend Service Parts per 1,000 Units.

Caution : 1. PCB assembly with mark (NLA) is no longer available after production discontinuation of the complete set.

2. When you order the aforementioned parts, be sure to specify "Part No." of the parts ordered.

15. REPLACEMENT PARTS LIST FOR PCB (1)

MODEL : JU - 475 - 4AGG

Ref.No.	Part No.	Part Name & Description	Pcs	RSP	Remarks
C2	ECEA1EKS330E	Electrolyte Capacitor	1		
C3	SR585F105Z	Ceramic Capacitor	1		
C4	MCH215F103ZK	Chip Capacitor	1		
C5	ECEA1EKS330E	Electrolyte Capacitor	1		
C6	MCH212F104ZK	Chip Capacitor	1		
C7 · 8	FCC00320B821	Chip Capacitor	2		
C9	MCH215A271JK	Chip Capacitor	1		
C10	MCH215C102KK	Chip Capacitor	1		
C11 · 12	FCC00320B223	Chip Capacitor	2		
C13	MCH215A391JK	Chip Capacitor	1		
C14	MCH215A101JK	Chip Capacitor	1		
C15 · 16	MCH215F223ZK	Chip Capacitor	2		
C17	MCH212F104ZK	Chip Capacitor	1		
C20 · 21	FCC00330B103	Chip Capacitor	2		
C25 · 26	MCH212F104ZK	Chip Capacitor	2		
C27	ECEA1EKS330E	Electrolyte Capacitor	1		
C28	MCH212F104ZK	Chip Capacitor	1		
C29	ECEA1EKS330E	Electrolyte Capacitor	1		
C30	MCH212F104ZK	Chip Capacitor	1		
C31	ECEA1EKS330E	Electrolyte Capacitor	1		
C32	MCH215F103ZK	Chip Capacitor	1		
C34	MCH212F104ZK	Chip Capacitor	1		
D1	MA151WK-TX	Diode	1		
D2 · 3	MA122-TX	Diode	2		
D4	MA121-TX	Diode	1		
D8 · 9	DA116-T96	Diode	2		
D12 · 13	MA157-TX	Diode	2		
IC1	FQL01280B4	LSI	1	2	
IC2	HA13421PMP	LSI	1	2	
IR1	RYLA6J102	Block Resistor	1		
J2	FJC00450B401	Connector	1		
J3	FJC01210B4	Connector	1		
J4	08052539	Connector	1		
J5	S05B-DR	Connector	1		
J7	S04B-DR	Connector	1		
J8	S02B-DR	Connector	1		
L2	FBR06HA850NA	Choke Coil	1		
L3	SFC24050202	Choke Coil	1		
L4 · 5	NL322522-181	Choke Coil	2		
L6	NL322522-680	Low-Frequency Coil	1		
L7 · 8	ELEPG330KA	Choke Coil	2		

REPLACEMENT PARTS LIST FOR PCB (2)

MODEL : JU - 475 - 4AGG

Ref.No.	Part No.	Part Name & Description	Pcs	RSP	Remarks
Q1	XN4212-TX	Transistor	1	2	
Q2	3SK144-TX	Transistor	1	2	
Q5 · 8	UN2211-TX	Transistor	2	2	
Q6	UN2111-TX	Transistor	1	2	
R1 - 9	FRA00100B151	Chip Resistor	9		
R10	ERJ6GEYJ392V	Chip Resistor	1		
R11	ERJ6GEYG392V	Chip Resistor	1		
R12	ERJ6GEYG512V	Chip Resistor	1		
R13	ERJ6GEYJ392V	Chip Resistor	1		
R15	ERJ6GEYJ392V	Chip Resistor	1		
R16	ERJ6GEYJ104V	Chip Resistor	1		
R18 - 20	ERJ6GEYJ163V	Chip Resistor	3		
R21	ERJ6GEYJ822V	Chip Resistor	1		
R22	ERJ6GEYJ821V	Chip Resistor	1		
R23	ERJ6GEYJ392V	Chip Resistor	1		
R24	ERJ6GEYJ331V	Chip Resistor	1		
R25 · 26	FRA00100B151	Chip Resistor	2		
R28	ERJ6GEYG363V	Chip Resistor	1		
R29	ERJ6GEYG203V	Chip Resistor	1		
R30	ERJ6GEYG363V	Chip Resistor	1		
R31	ERJ6GEYG203V	Chip Resistor	1		
R32	ERJ6GEYG363V	Chip Resistor	1		
R33	ERJ6GEYG203V	Chip Resistor	1		
R34	ERJ6GEYG363V	Chip Resistor	1		
R35	ERJ6GEYG203V	Chip Resistor	1		
R36	ERJ6GEYJ392V	Chip Resistor	1		
R37 - 39	ERJ6GEYJ102V	Chip Resistor	3		
R40	ERJ6GEYJ163V	Chip Resistor	1		
R41 · 42	ERJ6GEYJ362V	Chip Resistor	2		
R43	ERG1SJ271V	Metal Film Oxide Resistor	1		
R44	ERG1SJ151V	Metal Film Oxide Resistor	1		
R45	ERJ6GEYJ104V	Chip Resistor	1		
R46	ERJ6GEY0R00V	Chip Resistor	1		
R47 · 48	ERJ6GEYJ471V	Chip Resistor	2		
R49	ERJ6GEYJ822V	Chip Resistor	1		
R50 · 51	ERJ6GEYJ393V	Chip Resistor	2		
R52 · 53	ERJ6GEYJ182V	Chip Resistor	2		
R54	ERJ6GEYJ221V	Chip Resistor	1		
R55	ERJ6GEYJ273V	Chip Resistor	1		
R56	ERJ6GEYJ473V	Chip Resistor	1		
R57	ERJ6GEYJ392V	Chip Resistor	1		
R58	ERJ6GEYG203V	Chip Resistor	1		
R59 · 60	ERJ6GEYJ102V	Chip Resistor	2		
R61	ERJ6GEYJ4R7V	Chip Resistor	1		
R62 · 63	ERJ6GEYJ392V	Chip Resistor	2		
VR1	PK502H203HOD	Variable Resistor	1		
X1	EFO-GC3205C4	Resonator	1		

16. SCHEMATIC DIAGRAM [JU-475-4AGG]

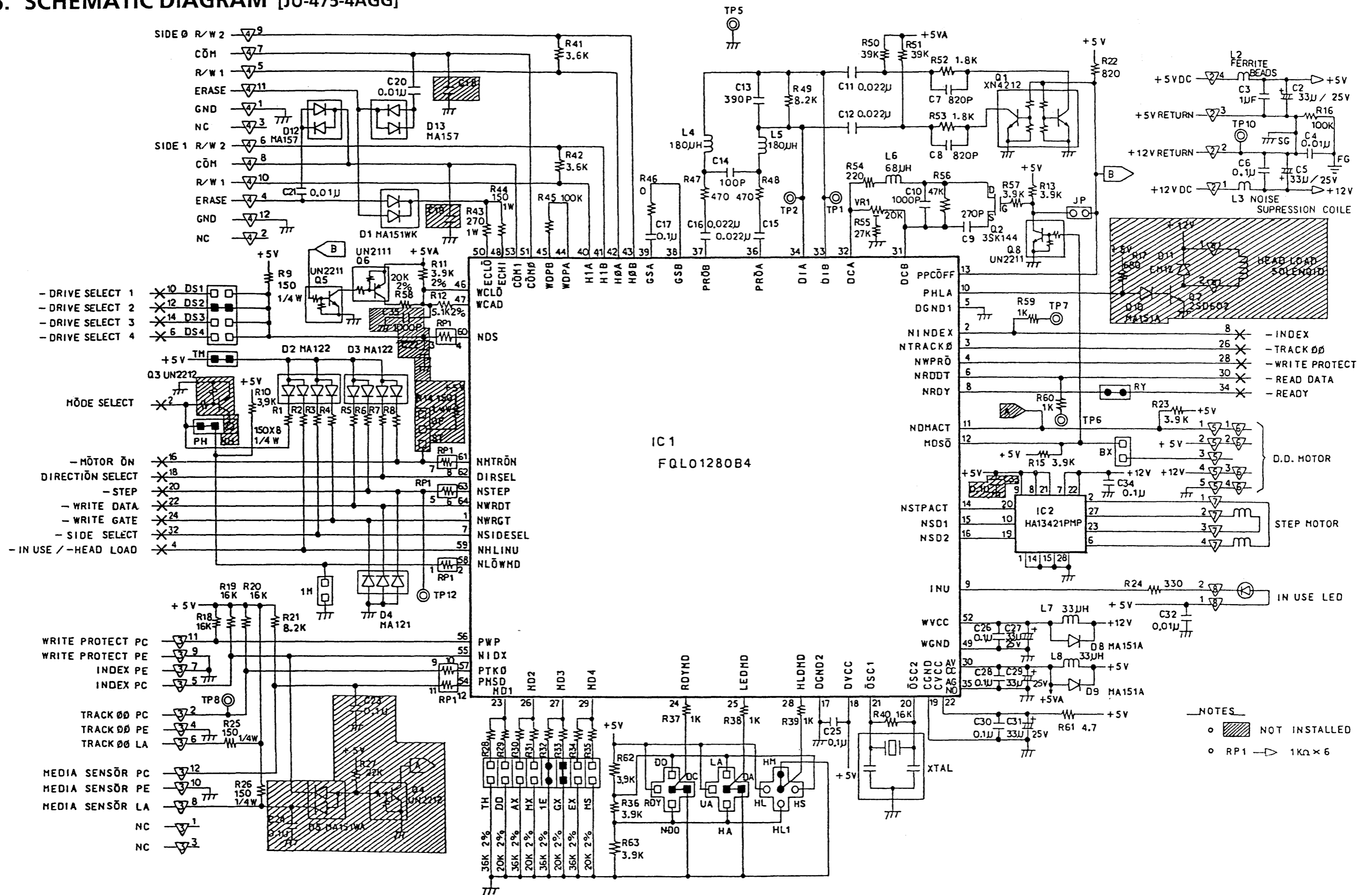

- NOTES**
- (hatched) NOT INSTALLED
 - RP1 → 1KΩ × 6

17. CIRCUIT BOARD [JU-475-4AGG]
Component Side (Top)

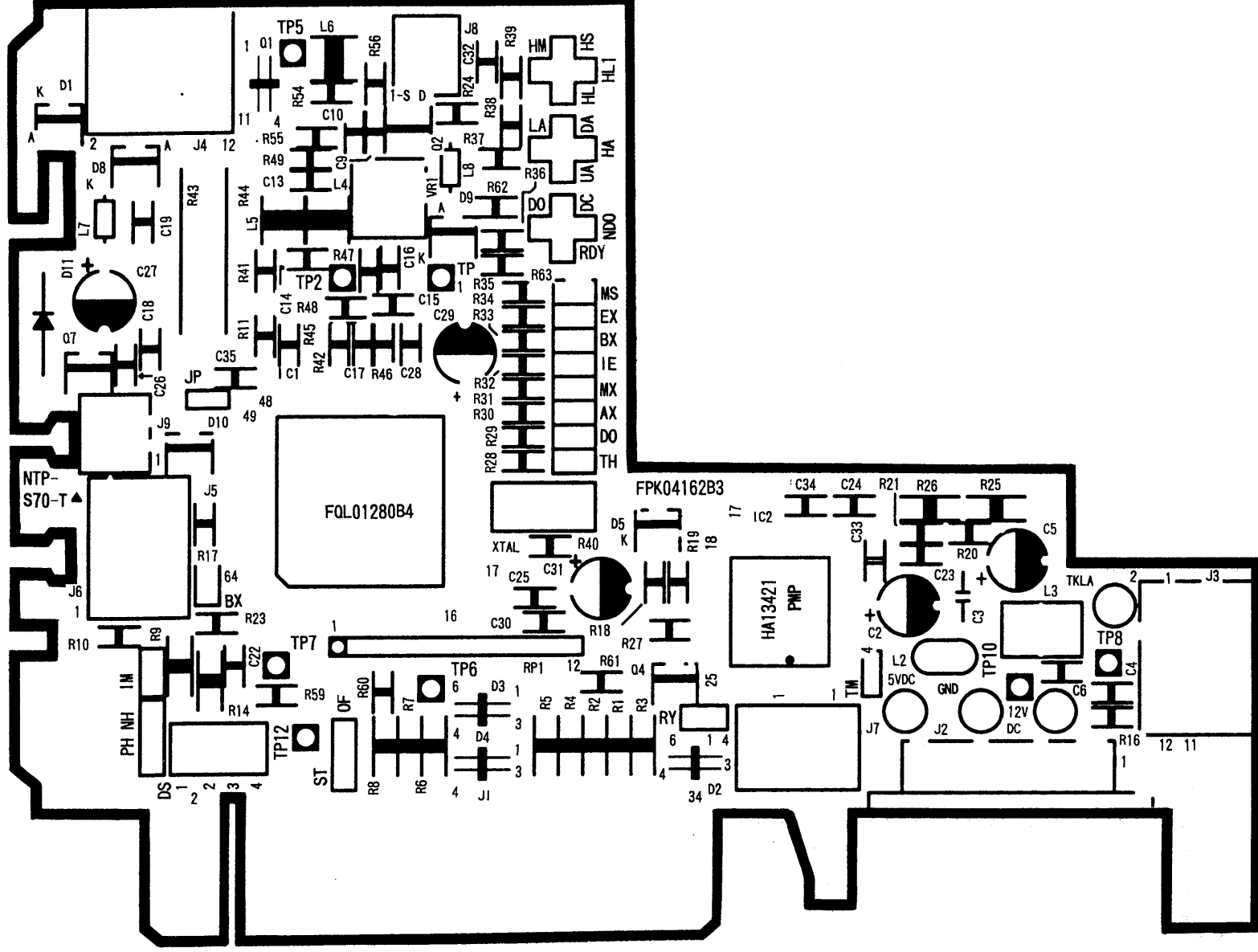

CIRCUIT BOARD [JU-475-4AGG]
Solder Side (Bottom)

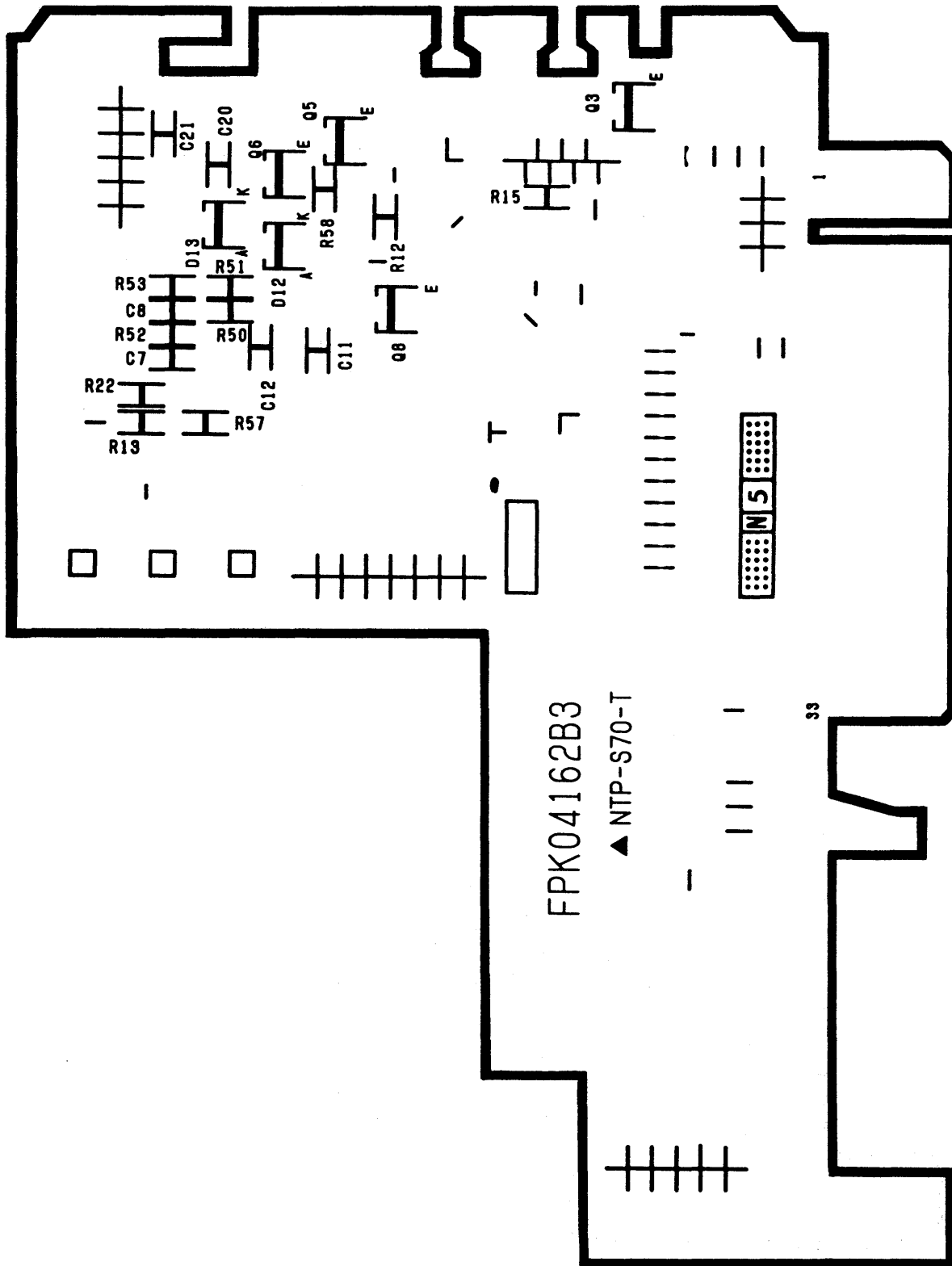

18. BLOCK DIAGRAM [JU-475-4]

